



Instructions for Continued Airworthiness

McFarlane Aviation, LLC. FAA-PMA Part Number MC0743624-1 Shimmy Dampener Assembly.
FAA PMA Number: PQ3732CE

Notice: Verify that this document is the latest approved revision before use! Current version can be found at:
www.McFarlaneAviation.com/ICA

Approved By:

Quality Assurance Manager

Engineering Manager

Production Manager



Revisions

Revision	Author	Date	Summary
Original	CAC	03/24/2021	Original release
A	ARH	08/22/2023	Rewritten
B	VRYJ	10/17/2023	Updated troubleshooting section
C	ARH	04/26/2024	Added safety cable option

List of Effective Pages

Page	Rev	Date
ALL	Original	03/24/2021
ALL	A	08/22/2023
9	B	10/17/2023
8, 9	C	04/26/2024

Contents

INTRODUCTION.....	3
SPECIAL OPERATING INFORMATION	3
PART REMOVAL, REPLACEMENT, AND SERVICE INFORMATION.....	3
TROUBLESHOOTING	9
PLACARDS.....	9
DATA.....	10
INSPECTION	10
RECOMMENDED OVERHAUL PERIODS	10
AIRWORTHINESS LIMITATIONS	10
ASSISTANCE & REVISIONS	10

INTRODUCTION

This document is intended to provide for the continued airworthiness of McFarlane Aviation, LLC. PMA replacement shimmy dampener assembly, part number MC0743624-1, eligible for installation on various Textron aircraft. For all items not related to the installation of the McFarlane Aviation, LLC. shimmy dampener assembly, refer to the basic airplane model service and parts manuals.

Table 1: McFarlane PMA Part Eligibility

Cessna P/N	McFarlane P/N	Aircraft Eligibility
0743624-1	MC0743624-1	182K, 182L, 182M, 182N, 182P, F182P, 182Q, F182Q, 182R, 182S, 182T, T182, T182T
SE1068-3		
SE1068-4		
SE1068-5		
SE1068-6		

SPECIAL OPERATING INFORMATION

The control and operation of the nose gear does not change with the installation of the McFarlane Aviation, LLC. Shimmy Dampener Assembly; see applicable Cessna/Textron Service Manual for the operational information.

PART REMOVAL, REPLACEMENT, AND SERVICE INFORMATION

Remove the old shimmy dampener and install the McFarlane replacement shimmy dampener assembly, part number MC0743624-1, per the applicable Cessna/Textron Model Service Manual.

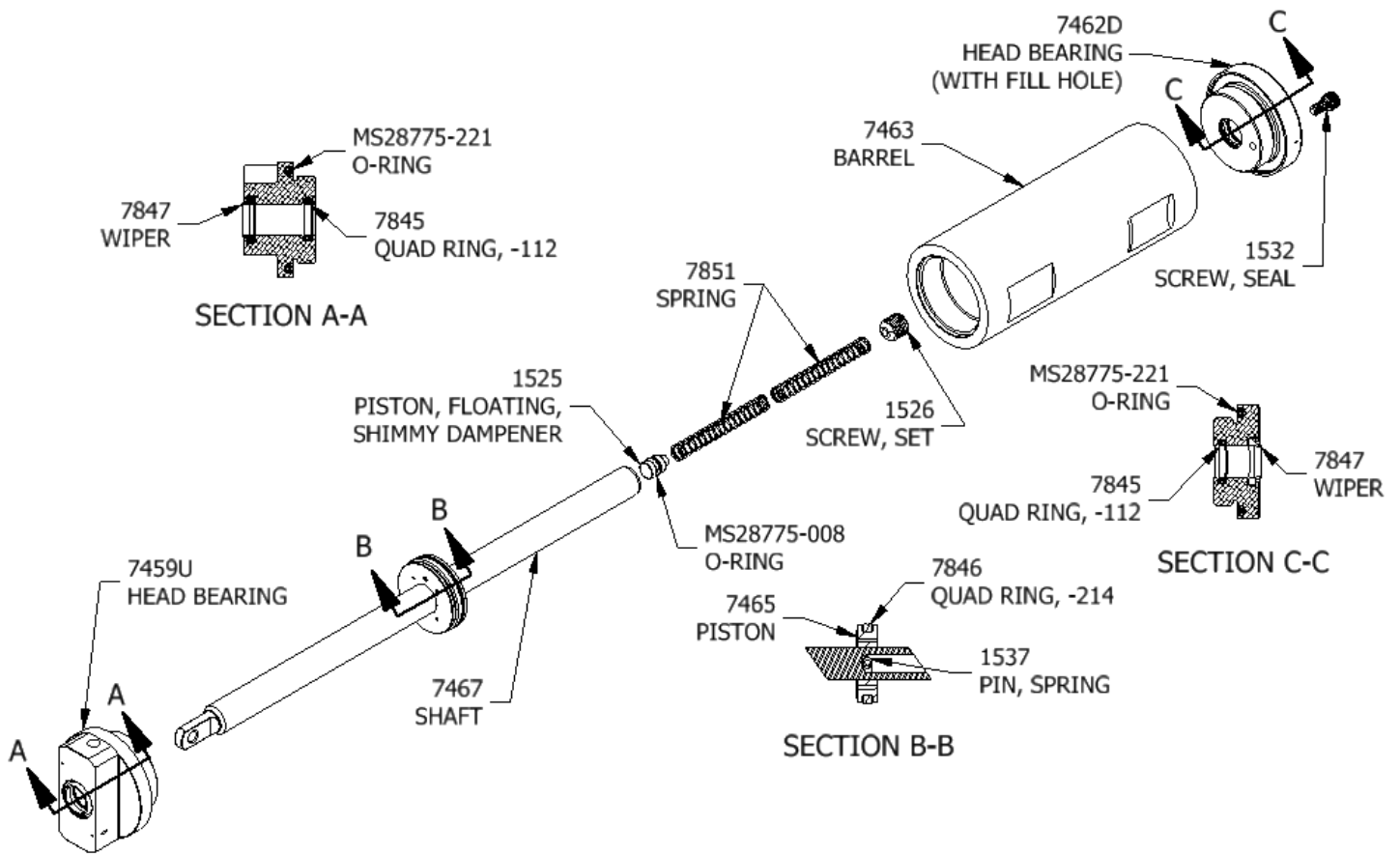

Figure 1: Subcomponent Part Numbers

The following service information is to be utilized when servicing the McFarlane Shimmy Dampener Assembly. NOTE: McFarlane Aviation, LLC. seal kit SDKT-8 and replacement parts are available for purchase if the originals are not re-usable (See Figure 1 for subcomponent part numbers).

CHECKING FLUID LEVEL (CHECK EVERY 50 HOURS)

- 1) The ambient temperature must be between 50 and 95 degrees Fahrenheit to check the fluid level. Do not check the fluid level if the shimmy dampener is not at the same temperature as the ambient air (i.e., the plane has been flown recently and the engine is still hot). This will skew the results.
- 2) If the fluid level cannot be checked with the shimmy dampener mounted on the aircraft, remove the shimmy dampener from the aircraft per the applicable Cessna/Textron Model Service Manual.
- 3) Measure the floating piston position in the shaft by inserting the floating piston tool into the vent hole of the set screw.

Note: The floating piston tool (Part Number 1530-1) is included with each shimmy dampener. If you don't have a floating piston tool, either purchase a new one from McFarlane (the tool will also be necessary for fluid addition and servicing of the shimmy dampener) or refer to "CHECKING FLUID LEVEL WITHOUT FLOATING PISTON TOOL".

Insert the tool until it contacts the nearest face of the floating piston (See Figure 2 and Figure 3). Do not thread the tool into the floating piston; this will result in an erroneous measurement.

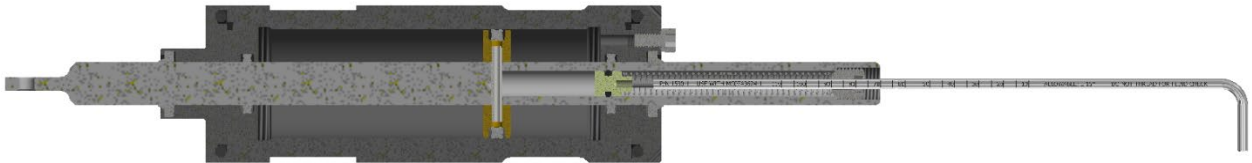

Figure 2: Section View of Fluid Check Procedure

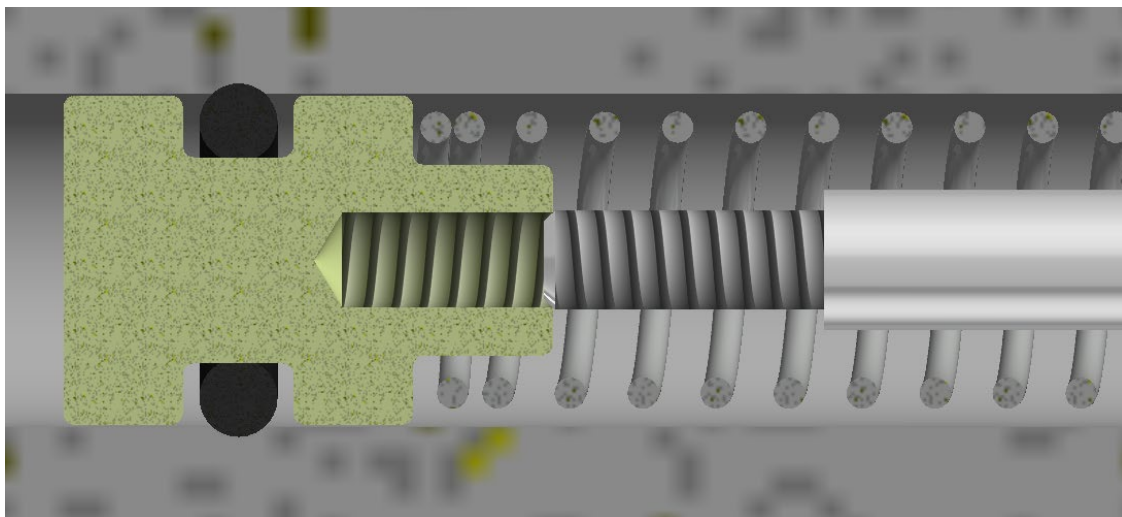

Figure 3: Section View of Fluid Check Procedure (Detailed)

- 4) If the reading on the tool is within 15°F of the ambient air temperature, the fluid level in the shimmy dampener is within tolerance (See Figure 4). Reinstall the shimmy dampener per the Cessna/Textron Model Service Manual.

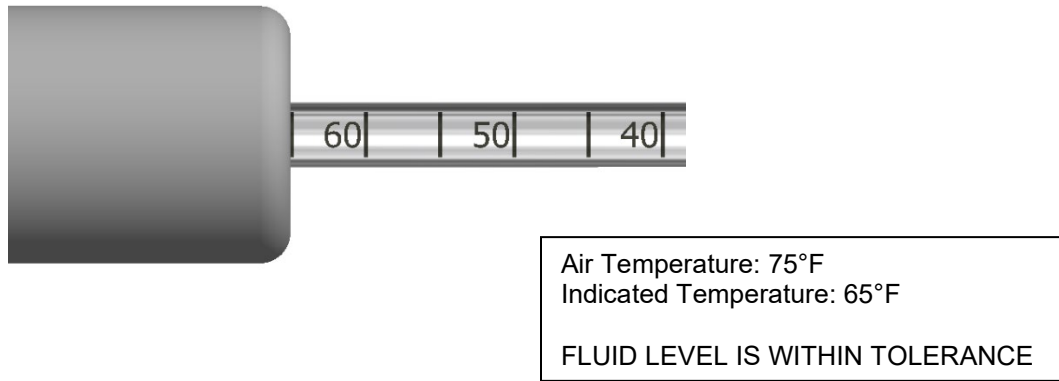

Figure 4: Fluid Check Example (Fluid Level within Tolerance)

- 5) If the difference between the reading on the tool and the ambient air temperature is greater than 15°F, the fluid level must be adjusted (See Figure 5); complete “HYDRAULIC FLUID LEVEL ADJUSTMENT”.

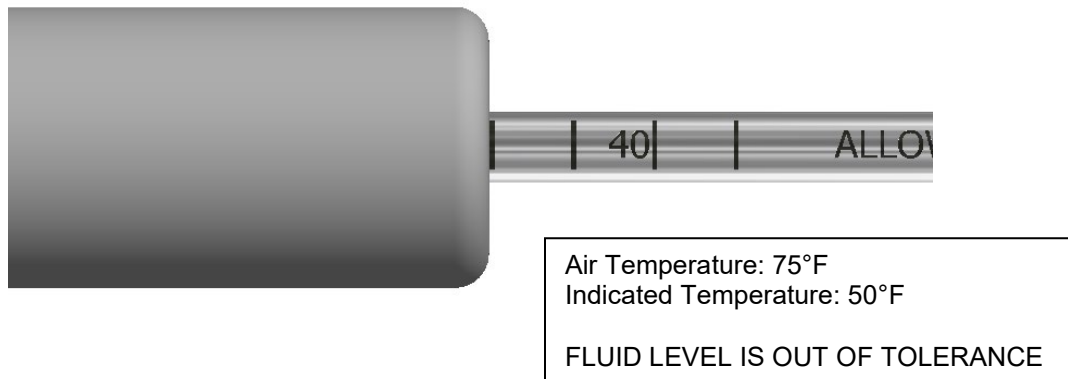

Figure 5: Fluid Check Example (Fluid Level out of Tolerance)

CHECKING FLUID LEVEL WITHOUT FLOATING PISTON TOOL

- 1) If you don't have the floating piston tool, checking the fluid can also be accomplished with a properly sized zip tie (used in this example) or a similar object.
- 2) The ambient temperature must be between 50 and 95 degrees Fahrenheit to check the fluid level. Do not check the fluid level if the shimmy dampener is not at the same temperature as the ambient air (i.e., the plane has been flown recently and the engine is still hot). This will skew the results.
- 3) If the fluid level cannot be checked with the shimmy dampener mounted on the aircraft, remove the shimmy dampener from the aircraft per the applicable Cessna/Textron Model Service Manual.
- 4) Ensure that the end of the zip tie will fit through the hole in the set screw (diameter: 0.134”) but not enter into the threaded hole in the floating piston (diameter: 0.089”), as this will result in an erroneous measurement.

Note: if using a zip tie, be sure to cut off the tapered end so that it will not enter the threaded hole of the floating piston, causing an erroneous measurement.

- 5) Mark the zip tie using the MAX and MIN values from Table 2 that correspond with the ambient air temperature.

Table 2: Floating Piston Position Limits

Temperature (°F)	MAX MIN (in)
50	3.88 3.02
55	3.74 2.88
60	3.60 2.74
65	3.45 2.60
70	3.31 2.45
75	3.17 2.31
80	3.02 2.17
85	2.88 2.02
90	2.74 1.88
95	2.60 1.74

- 6) Insert the zip tie into the shaft through the hole in the set screw until it contacts the nearest face of the floating piston.
- 7) If the end of the shaft falls between the marks on the zip tie, the fluid level is within tolerance. If the end of the shaft does not fall between the marks on the zip tie, the fluid level is out of tolerance and “HYDRAULIC FLUID LEVEL ADJUSTMENT” must be completed.

HYDRAULIC FLUID LEVEL ADJUSTMENT

See Figure 1 for reference.

- 1) The ambient air and hydraulic fluid temperature must be approximately 70°F to complete this step.
- 2) If it hasn't been removed already, remove the shimmy dampener from the airplane per the applicable Cessna/Textron Model Service Manual.
- 3) Position the shaft all the way to the end with the non-fill hole head bearing. Position the shimmy dampener so the barrel is vertical with the seal screw on the top of the assembly. See Figure 6 for Reference.

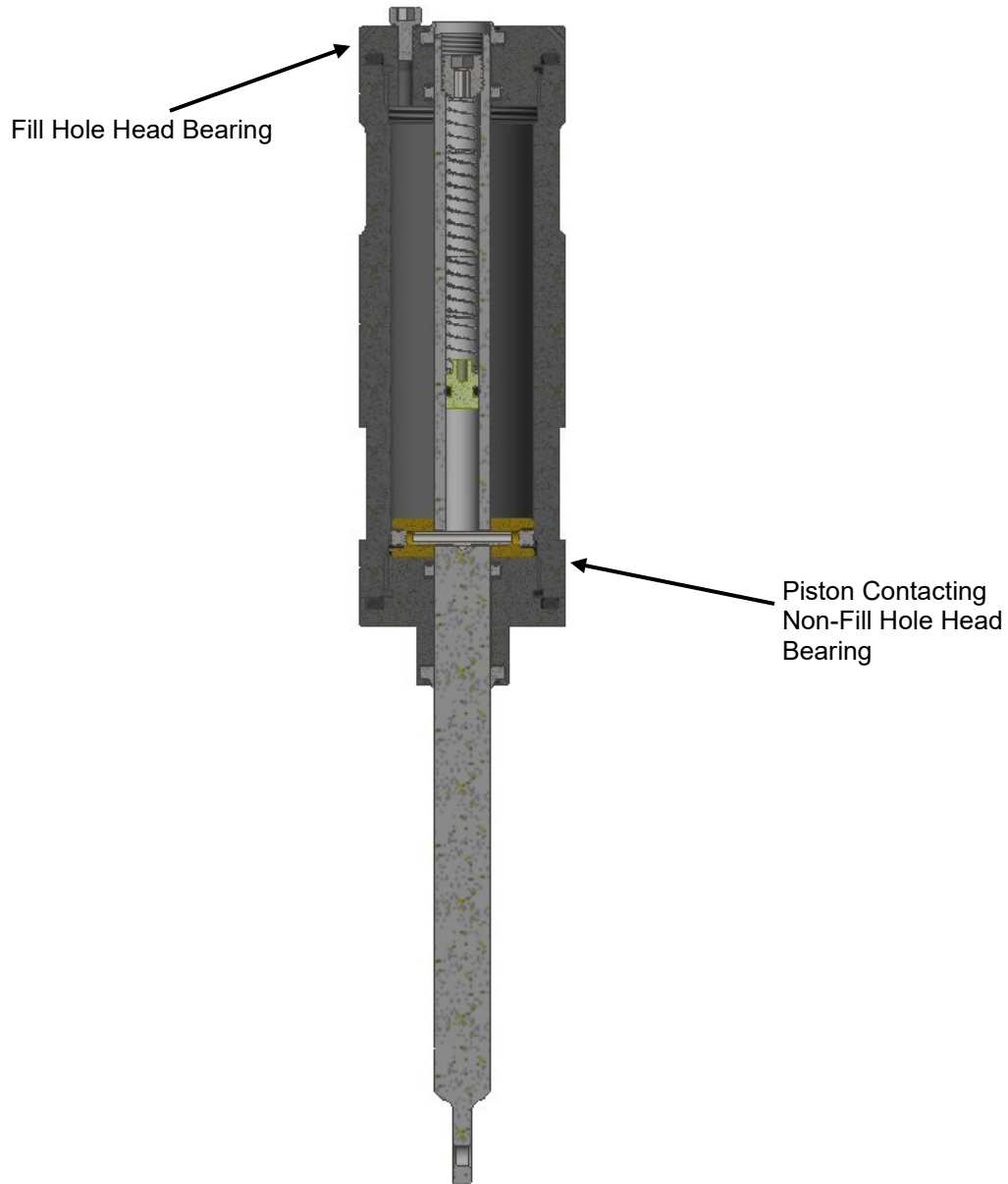

Figure 6: Filling Configuration

- 4) Remove the seal screw.
- 5) Remove the set screw, spring(s), and floating piston.
- 6) Fill the shimmy dampener with MIL-PRF-5606 hydraulic fluid through the fill hole in the head bearing until the fluid fills up the shaft.
- 7) Wait 30 minutes to allow any air bubbles to rise out the shimmy dampener.
- 8) Top off the shimmy dampener with hydraulic fluid if the fluid level has decreased.
- 9) Thread the floating piston tool fully into the floating piston and slowly insert the floating piston into the shaft until the engraved line on the floating piston tool is aligned with the end of the shaft (See Figure 7). Unthread and remove the floating piston tool.

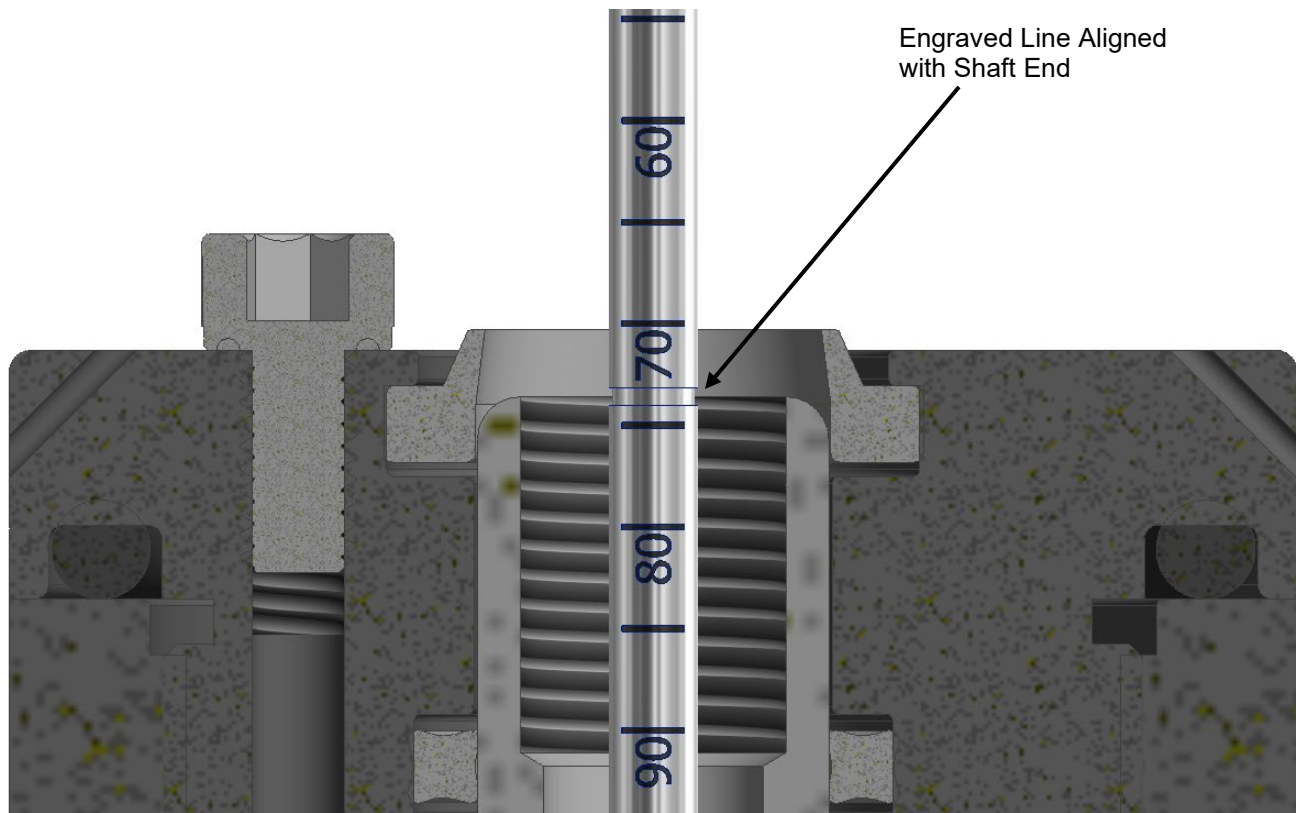

Figure 7: Floating Piston Placement

- 10) Install the seal screw.
- 11) Install the spring(s) and set screw.
- 12) Cycle the unit by hand. If the movement is erratic or a gurgling sound is heard, there is still air in the shimmy dampener.
- 13) If a significant amount of air is identified, cycle the shimmy dampener several more times to work it out, then restart at step 3 of this section.
- 14) Check for proper “feel” while cycling. The shaft should move relatively easily at low speeds but resist significantly at high speeds. If this is not the case, the shimmy dampener may have failed or been improperly assembled, complete “DISASSEMBLY AND INSPECTION.”
- 15) Clean the shimmy dampener with a cleaning agent and dry with a clean cloth.
- 16) Re-install the shimmy dampener on the airplane per the applicable Cessna/Textron Model Service Manual.

DISASSEMBLY AND INSPECTION

- 1) Cut and remove the safety wire or safety cable.
- 2) Remove the seal screw, set screw, spring(s), and floating piston.
- 3) Drain the hydraulic fluid.
- 4) Remove the head bearings by unthreading them from each end of the barrel.
- 5) Remove the shaft assembly from the barrel.
- 6) Examine the following parts: Barrel, Head Bearings, Piston, Shaft, Floating Piston. Replace them if there are any scratches, gouges, excessive wear, or corrosion (minor discoloration or small scratches are acceptable). If the anodize (black coating) has come off at all on the bearing surface of the head bearings or the inner bore of the barrel, that part must be replaced.

- 7) Examine all the seals and replace them if any flattening or knicks are present.
- 8) Ensure none of the holes in the piston are plugged.
- 9) If the piston must be removed from the shaft, remove the piston seal and use a 1/8" punch to eject the roll pin.
- 10) Clean all parts in a petroleum solvent or mild water/detergent solution. All parts must be rinsed, cleaned, and dried.

ASSEMBLY

- 1) Before you assemble the shimmy dampener, make sure there are no sharp edges on the parts that can result in damage of the seals when assembled.

CAUTION: Dirt and dust can cut the seals in the barrel. Keep all parts clean during assembly.

- 2) If removed, install the piston to the shaft using the roll pin (Note: ensure that all holes in the piston line up with those on the shaft).

CAUTION: Make sure to support the piston and shaft with a soft material while installing the piston to the shaft to avoid denting or bending the parts.

- 3) Replace all seals and any other damaged parts (Note: All Replacement parts and Seal Kit P/N SDKT-8 are available for individual purchase).
- 4) Lubricate all internal parts with MIL-PRF-5606 hydraulic fluid.
- 5) Ensure there are no knicks or sharp edges; these could cut the seals.
- 6) Install the shaft assembly in the barrel.
- 7) Install the head bearings onto the shaft and thread them into the barrel. Ensure the shaft orientation, with respect to the head bearings, is correct (see Figure 1). Tighten the head bearings to the barrel with a torque of 50 ft-lbs.
- 8) Secure the head bearings together using .032" safety wire or safety cable.
- 9) Perform "HYDRAULIC FLUID LEVEL ADJUSTMENT" steps 3, 6-16.

NOTE: PRE-FLIGHT CHECK LIST AND 100 HOUR AIRCRAFT INSPECTION ARE NOT ALTERED AS A RESULT OF THIS INSTALLATION.

TROUBLESHOOTING

- **ERRATIC MOVEMENT OR GURGLING SOUND HEARD:** When cycling the unit by hand, if the movement is erratic or a gurgling sound is heard, there is air in the shimmy dampener. If a significant amount of air is identified, cycle the shimmy dampener several more times to work it out, then complete "HYDRAULIC FLUID LEVEL ADJUSTMENT" procedure.
- **IMPROPER STEERING CHARACTERISTICS:** Remove the shimmy dampener from the aircraft. Check for proper "feel" while cycling the shimmy dampener by hand. The shaft should move relatively easily at low speeds but resist motion significantly at high speeds. If this is not the case, start by performing the "CHECKING FLUID LEVEL" procedure and adjust fluid level if needed. If problem persists, complete the "DISASSEMBLY AND INSPECTION" procedure.
- **FLUID LEAKAGE:** Complete "DISASSEMBLY AND INSPECTION" procedure to determine cause of leakage.

PLACARDS

None applicable

DATA

None applicable

INSPECTION

Every 50 Hours: Complete "CHECKING FLUID LEVEL" and inspect the exterior of the shimmy dampener for any major knicks or other defects. Ensure there is no major fluid leakage.

RECOMMENDED OVERHAUL PERIODS

No additional overhaul time limitations exist with the use of these parts.

AIRWORTHINESS LIMITATIONS

The Airworthiness Limitations section is FAA approved and specifies maintenance required under Sec. 43.16 and 91.403 of the Federal Aviation Regulations unless an alternative program has been FAA approved. No additional airworthiness limitations exist.

ASSISTANCE & REVISIONS

ICA revisions shall be made available on the McFarlane website, www.mcfarlaneaviation.com/ICA. For questions or assistance regarding these Instructions for Continued Airworthiness (ICA), contact McFarlane Aviation, LLC. via email or phone.

Email: engineering@mcfarlaneaviation.com

Phone: 1-800-544-8594 (within the US) or 1-785-594-2741